

## **TECHNICAL BULLETIN**

### **2010 Formula Ford - Technical Regulations**

#### **REFERENCE:**

*CAMS Online Manual of Motor Sport, Race, 1<sup>st</sup> Category: Racing Cars, Formula Ford*

[http://www.camsmanual.com.au/02\\_race.asp#1st](http://www.camsmanual.com.au/02_race.asp#1st)

#### **RATIONALE:**

*To implement changes to the 2010 Technical Regulations for Formula Ford.*

#### **ACTION:**

*Amend the Formula Ford Technical Regulations as indicated in the following document.*

# Specifications of Automobiles

All vehicles in races and other speed events must comply with the General Requirements of Automobiles (see “General Requirements for Cars and Drivers” in the CAMS Manual of Motor Sport).

## 1st Category – Racing Cars

### Formula Ford - Technical Regulations



#### Category Manager (CM):

Australian Formula Ford Management Pty Ltd

#### PREAMBLE

Formula Ford has been adopted by CAMS as its progressive level open wheel circuit racing formula. CAMS is ultimately responsible for the approval of the regulations and changes thereto, and responsible for publishing the regulations via the CAMS Manual and associated bulletins as necessary. For Formula Ford using the original ‘Kent’ engine, please refer to the Formula Ford 1600 regulations approved by CAMS.

Vehicles shall conform with the General Requirements of Automobiles as laid down in “General Requirements for Cars and Drivers” in the CAMS Manual of Motor Sport and these regulations.

Prior to being issued with a log book, each Formula Ford car must be issued with a certificate of origin.

**These regulations shall be effective from 1 January 2010.**

#### 1. DEFINITION

FORMULA FORD is open to single-seater cars with open coachwork as defined by CAMS and complying with its Vehicle Regulations, using standard 1600cc Duratec engine described in Article 2 below (refer also to Schedules A, B and C [refer to “General Requirements for Cars and Drivers” in the CAMS Manual of Motor Sport] and the specifications for 1st Category - Racing Cars [see “Race” in the CAMS Manual of Motor Sport]). Only chassis manufactured after January 1, 2001 (identified with a manufacturer’s chassis plate confirming the date of construction) and complying with the requirements of Schedule J – Safety Cage Structures (see “General Requirements for Cars and Drivers”), are eligible to be fitted with the Duratec engine.

**ALL STANDARD COMPONENTS AND SETTINGS MUST REMAIN AS SUPPLIED BY FORD MOTOR CO. UNLESS THESE REGULATIONS STATE OTHERWISE.**

#### 2. ENGINE

- 2.1 Only the Ford 1600cc Duratec unit fitted to the WB Fiesta is permissible. Engines are to be purchased through the Category Manager. All engines will be supplied with four seals, one on each of the following: Front seal housing, rear seal housing, inlet camshaft and exhaust camshaft.  
**All engines will be individually identified with serial numbers.**
- 2.2 Engines will be mounted upright, and aligned fore and aft in the chassis, additionally the crankshaft centre line must be on the longitudinal centre line of the vehicle.
- 2.3 The addition of any material, be it metal, plastic or composite etc, by any means be it welding, bonding, encapsulation or encasement to any component, is prohibited. Specific repair of castings may be allowed with written approval of the Category Manager’s Technical Director.
- 2.4 Balancing of flywheel and clutch are permitted, provided only minimal localised weight is removed and meets the requirement of rule 2.9.7
- 2.5 The exhaust manifold must use the standard gasket and the Specified mounting flange at the cylinder head face. The primary pipes must be 38mm (1½”) OD, 800mm long and 1.6mm wall thickness. The secondary pipe must be 50mm (2”) OD and 1.6mm wall thickness. A Specified collector, available through the CM, must be fitted. **The external surface of the collector may be modified to fit locating clips and by painting. No other modification is permitted. The internal surface of the Specified collector must remain as supplied.**

Primary pipes will be measured by volume, the average volume of each pipe including the mounting flange shall be 760cc ± 2%. To allow for individual primary pipes it is permitted to section the mounting flange.

A muffler providing noise abatement complying with the requirements of CAMS must be fitted at all times during practice and racing.

**2.6 Lubrication System:** The Specified sump must be used. External to the engine, the only scavenge pump allowed is the Specified component; the remainder of the system is free. Oil coolers are free.

**2.7 Cooling System:**

**2.7.1** A water based liquid cooling system is mandatory.

**2.7.2** Through freedom of drive from the crankshaft to the pump, the rotational speed of the water pump may be changed.

Pulleys, belts and retention bolts driving the water pump are free.

**2.7.3** The thermostat housing and water outlet housings are free. The thermostat may be removed. The car water circulation concept must be retained.

**2.7.4** No other pump or motor may be used to circulate or assist circulation of the coolant liquid.

**2.8** Crankshaft pulley is free as are the drive belts and pulleys for the alternator and scavenge pump.

**2.9 Flywheel and Clutch**

**2.9.1** The flywheel must be the control component. No other machining is allowed. For rectification the clutch mating face may be resurfaced, providing the minimum weight is respected.

**2.9.2** The position of the ignition mark on the flywheel relative to the crankshaft must remain within Ford design limits at all times.

**2.9.3** The clutch plate must be the Specified component

**2.9.4** The clutch cover must remain standard.

**2.9.5** Flywheel bolts must remain standard.

**2.9.6** It is permitted to secure the ring gear to the flywheel.

**2.9.7** Flywheel minimum weight shall be 6.3kg (excluding all bolts).

**2.9.8** Flywheel and clutch cover minimum weight shall be 9.6kg (excluding all bolts).

Localised machining of the cylinder block is permitted only to allow fitting into the chassis. It is prohibited to remove any identification markings.

**2.10 Induction**

**2.10.1** The inlet manifold must be the Specified component.

**2.10.2** The throttle body must be the Specified component

**2.10.3** The air filter must be the Specified component.

**2.10.4** With the exception of ambient atmospheric air and the Specified control fuel, approved for use in the category, no other substance may be used to alter the intake charge of the engine.

**2.11** The use of non-standard replacement fasteners, nuts, bolts, screws, studs and washers which are not connected with or which do not support any moving parts of the engine or its compulsorily retained accessories is permitted. All engine gaskets must be standard. The use of thread locking compounds is permitted.

**3. FUEL SYSTEM**

**3.1** The **fuel pump** is free.

**Fuel Pressure:** With the engine at operating temperature, and the engine idling, the pressure at the fuel rail shall be 370kpa ± 10kpa with the manifold vacuum disconnected from the pressure regulator.

**3.2** Fuel **pipes** are free.

**3.3** Fuel **cooling radiators** are not permitted.

**3.4** Fuel **tanks:** Only FT3 or superior FIA specification tanks are permitted. Each new bladder fitted after 1 January 2008 shall be identified as being suitable for fuels containing ethanol.

**3.5** Only unleaded fuel as defined in Schedule G (refer "General Requirements for Cars and Drivers") may be used unless otherwise specified by CAMS.

Maximum capacity of fuel tank: **41 litres**

**3.6** A dry-break fuel sampling coupling at the fuel rail is mandatory.

**3.7** Any device or substance, which changes the temperature of the fuel from the ambient air temperature, is prohibited.

**4. TRANSMISSION**

**4.1** The gearbox must contain not more than four forward gears and include an operable reverse gear, capable of being engaged by the driver whilst normally seated.

The main cluster must be wholly behind the rear axle output shaft centre line, and parallel with the crankshaft centre line.

**Gear selection** must be via a direct mechanical connection to a “H-pattern” gear shift lever operated by the driver. Electronic, hydraulic or pneumatic assisted systems are prohibited.

**4.2** The gearbox **ratios** are free.

**4.3** **Rear-wheel** drive only is permitted.

**4.4** Final drive **ratio** is free.

Torque biasing, limited slip and locked differentials are prohibited. The use of non-ferrous material in differential components is prohibited, save that the Thrust Washer, Hewland Part No. HC8-214-5R, manufactured from plastic, is permitted in Hewland Gearboxes

## 5. CHASSIS

All Formula Ford chassis will be required to be constructed incorporating lateral protection structures as prescribed as follows:

A lateral protection structure is defined as continuous panels whose projection on a vertical plane parallel to the longitudinal axis of the car shall be at least 150mm high, shall extend on either side of the car, to a minimum distance of 550mm from the car's longitudinal centre line between at least the transverse planes passing through the fuel tank rear face and the frontal extremity of the minimum cockpit overall opening length, and at a minimum distance of 350mm from the car's longitudinal centre line between at least the transversal planes passing through the above extremity and the front rollover bar hoop.

These panels shall be made from a composite material of 3000mm<sup>2</sup> minimum cross section with a honeycomb core in metal or Nomex<sup>®</sup> giving adequate resistance to compression. The external skins shall be of aluminium alloy or plastic of a minimum thickness of 0.5mm or made up of another assembly of materials of equivalent efficiency. The panels must be securely attached to the bottom and at the upper extremity to the main structure of the car in such a manner as to ensure absorption of a lateral impact.

The radiators may play the role of protective panels or of transversal struts.

The periphery of the bodywork covering the lateral protection structure, when viewed from below, must be curved upwards with a minimum radius of 50mm, and a maximum radius of 70mm with the exception of air entry and exit openings into the lateral protection structure. The floor of the side pod must reflect the plan of the upper surface.

The floor is to be in the same plane as the undertray in both directions; ie, transverse and longitudinal, subject to all points being within 25mm of any flat plane situated under the car (see 5.1 below).

**5.1** The chassis must be of tubular steel construction with no stress-bearing panels except bulkheads and undertray; curvature of the undertray must not exceed 25mm.

Monocoque chassis construction is prohibited. Stress-bearing panels are defined as sheet metal affixed to the frame by welding, bonding or rivets or bolts or screws which have centres closer than 150mm. Bodywork must not be used as stress-bearing panels.

**5.2** All new chassis issued with a log book after 1 January 2007 must comply with the following:

Above the level of the lateral protection structure, and up to the level of the upper chassis tube, stretching from the rear roll hoop to the front roll hoop, there must be an anti-intrusion panel. This anti-intrusion panel shall be either built into the removable bodywork or keyed into the main chassis but cannot be rigidly attached to the chassis. It can be made from glass-reinforced plastic, Kevlar<sup>®</sup> or aluminium skin added to the inner face of the removable body panel. Any material added must considerably improve the anti-penetration capability of the structure in the area of the driver. If the side protection is built into the bodywork alongside the driver the minimum requirement is a double layer, 141.75g/m<sup>2</sup> (5oz), bi-directional, laminated Kevlar<sup>®</sup> (Aramid) material.

**5.3** The use of stabilised/composite materials using carbon fibre and/or Kevlar<sup>®</sup> reinforcement is prohibited, SAVE where specifically authorised

**5.4** No engine oil or water tubes are permitted within the cockpit.

**5.5** All cars must also comply with the following:

**5.5.1** the internal cross-sectional area of the cockpit from the soles of the driver's feet to behind his seat shall nowhere be less than 0.07m<sup>2</sup>. The minimum width must be 250mm over the whole length of the cockpit. The only intrusion permitted into the cross-sectional area is the steering column;

5.5.2 the driver's feet (in normal position, pedals not depressed) must be located behind a transverse vertical plane drawn through the front wheel axes.

5.6 No part of the car, except for tyres, may be closer to the ground than 40mm. This measurement will be taken with the driver seated at the steering wheel, the car in race trim and with the wheels pointed straight ahead.

### 5.7 Impact Absorbing Structure:

5.7.1 Each new chassis issued with a Log Book after 1 January 2008 must include an impact-absorbing structure fitted ahead of the front bulkhead of the tubular steel frame.

This structure must be independent of the main bodywork and must be solidly fixed to the extremities of the bulkhead (ie, with bolts requiring tools for removal). It must constitute a box of 300mm minimum length, 150mm minimum height in any vertical section and 40,000mm<sup>2</sup> minimum total cross section. It must be metallic using honeycomb sandwich construction with a panel thickness of 13.9mm minimum.

The main bodywork is defined as the external covering of the chassis frame from the foremost steel bulkhead to the centreline of the rear wheels.

5.7.2 The impact-absorbing structure shall be fixed to the chassis with a minimum of four fasteners, in high quality steel using a core diameter of 6mm minimum.

Irrespective of the size of the impact absorbing structure (safety foot box), the maximum total area of access holes allowed in the walls of this structure shall be 15,000mm<sup>2</sup>.

The basic structure is defined as a unit with five closed sides and one open side. The access hole dimensions quoted apply to any modification to the five closed sides. (Minimum clearance holes for the passage of steering rack/rods are not included in the calculation of this area.)

## 6. WHEELS AND TYRES

6.1 Each car must be fitted only with the Specified Performance alloy wheels, as detailed below:

Front	13" x 6"	Part no. 100FF	100mm PCD
	or	Part no. 095FF	95mm PCD
Rear	13" x 7"	Part no. 100FF	100mm PCD
	or	Part no. 095FF	95mm PCD

6.2 **Wheel colours: Painting of Specified Wheels is not permitted. Performance Wheels are available in a choice of metallic or black finishes.**

6.3 For safety reasons, it is strongly recommended that weekly checks are carried out and that wheels are renewed at least once every year.

6.4 **Wheel Bearings: Only wheel bearings manufactured from ferrous materials are permitted.**

6.5 The make, type, specification and dimensions of the tyres permissible for use in Formula Ford racing shall be advised from time to time.

The permissible tyres are:

- Avon ACB10 Semi Slick compound cross-ply

Front: 7317 MX 6.0/21.0 x 13

Rear: 7319 MX 7.0/22.0 x 13

6.6 At the start of any race or timed official practice the depth of tread must be at least 1mm, save that isolated flat spots may not render a tyre ineligible.

## 7. STEERING GEAR

The complete steering system is free.

## 8. BRAKES

8.1 Vehicle must be fitted with brakes that are operative and capable of stopping the vehicle as required.

8.2 Only brake discs made predominantly from ferrous material are permitted.

8.3 Calipers may be ferrous or aluminium alloy castings with a maximum of two working cylinders per caliper.

8.4 Be equipped with two independent brake circuits, so that, in event of failure of one system, braking is maintained on at least two wheels.

- 8.5 Vehicles must have brakes on all wheels.
- 8.6 Vehicles must not be fitted with an anti-lock braking system.
- 8.7 Brake cooling ducts are not permitted.
- 8.8 Cross-drilling of brake discs is prohibited.
- 8.9 Until further notice, competitors are required to use Ferodo brake pads, compound numbers either DS2500, DS3000 or DS4300.

## 9. SUSPENSION AND RUNNING GEAR

- 9.1 All parts of the **suspension system** must be of steel or ferrous material, with the exception of bellcranks, tracking or alignment arms, hubs, hub adaptors, hub carriers, bearings and bushes, spring caps, abutment nuts and anti-roll bar links.
- 9.2 **Active suspensions** are prohibited, as is any system which allows control of the flexibility of the suspension springs, shock absorption and trim height whilst the car is moving.
- 9.3 The use of **titanium** is prohibited.
- 9.4 **Shock absorbers** are free, save that vehicles cannot be fitted with more than four; ie, no more than two at the front and rear. Interconnection of fluid between units and mechanical interconnection between front and rear units is not permitted.

## 10. ELECTRICAL EQUIPMENT

- 10.1 The standard **alternator** must be operational at all times during competition. **Location is free.**
- 10.2 **Spark plugs** are free, provided they are a standard replacement for the engine.
- 10.3 It is permitted to replace the nose housing of the standard **starter motor**.
- 10.4 The Specified **ignition coil** must be used and may not be re-positioned.
- 10.5 The Specified engine **wiring loom** must be used.
- 10.6 The Specified water temperature and oil pressure sensors must be used.
- 10.7 The Specified **ECU** must be used. For the avoidance of doubt, firmware software and settings (maps) shall be regarded as part of the ECU. The ECU diagnostic connector must be positioned in an accessible position allowing scrutineers free access to it at all times including if the driver is seated in the car and fully prepared to take part in the competition.
- 10.8 A LED, rearward facing, red warning light must be located within 100mm of the vehicle centre line and be clearly visible from the rear. The minimum light intensity must be 200,000 mcd with a minimum viewing angle of 6°. The centre of the light must be placed not less than 300mm from the ground, and less than 300mm from the rearmost part of the car.

## 11. BODY

- 11.1 Any **device** designed to aerodynamically augment the downthrust on the vehicle is prohibited. These devices specifically include aerofoils, venturi tunnels, skirts, nose fins and spoilers of any kind. Integration of aerofoils and spoilers by design or the mismatching of bodywork and/or chassis panels and members is also prohibited.  
**The bodywork must totally enclose the engine inlet manifold and filter with an opening for the passage of air. The uppermost surface of the bodywork must not extend more than 25mm above the top surface of the rollover hoop. See additional note in dimensions table, Appendix A.**
- 11.2 The **upper rear** bodywork (located above the wheel centreline) is permitted to extend rearwards for a maximum of 375mm from a line drawn through the rear wheel axis. The maximum height at any part wider than 1100mm ahead of the front wheels is not to exceed the front wheel rim height.
- 11.3 The **shape** of the bodywork behind a vertical line drawn from the highest point of the roll over bar must not include any reflex curves or flat surfaces which are capable of augmenting downthrust.
- 11.4 The **lower rear** bodywork (located below the wheel centreline) is only permitted alongside and beneath the engine and may only extend from behind the cockpit to a line drawn through the rear wheel axis. The incorporation of suspension or other fairings in this bodywork is prohibited.
- 11.5 It is not permitted to construct any suspension member in the form of an aerofoil or to incorporate a spoiler in the construction of any suspension member.  
The use of suspension fairings separate from this bodywork is prohibited.
- 11.6 The use of composite materials using carbon fibre reinforcement is prohibited.
- 11.7 **Roll over protection:** A roll bar is required to be fitted behind the driver's head. It must be configured so that the top of the driver's helmet is 50mm vertically below the top of the roll bar, and at least below a line drawn from the top of the roll hoop to the top of the front bulkhead (see points 1 and 2 on the diagram accompanying the table of dimensions).  
The roll bar must be either:

1. made from 38mm x 2.5 mm cold drawn seamless tubing and comply with the configuration shown as Type 1; or
2. an alternative design capable of withstanding a vertical load of 36.4kN and a load of 26.7kN applied at the top of the roll bar and directed horizontally to the rear. Such a design must be certified by CAMS or another ASN.

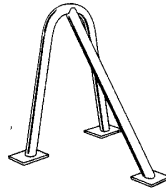

**Type 1: Solo Roll Bar**

- 11.8 Seat belts** must be fitted in accordance with the requirements of Schedule I (see “General Requirements for Cars and Drivers”).
- 11.9 Nose boxes/cones** manufactured in ferrous materials (eg, steel) are prohibited.
- 11.10** Any new chassis issued with a Log Book after 1 January, 2007 must comply with the following: The opening giving access to the cockpit must allow a designated horizontal template to be inserted vertically into the cockpit (not considering the steering wheel, the removable seat or any side head support) down to 250mm lower than the lowest point of the cockpit opening. This template is defined by dimensions J, K, L in the Table of Dimensions.

## 12. WEIGHT

The minimum racing weight at any time including the driver with helmet and wearing all apparel (eg, as at the end of a race or practice) shall be 495kg as recorded on the scales at the circuit on the day of the meeting. Any ballast which is carried must be securely fixed (eg, welded, riveted or bolted) and located in a position able to be readily checked.

## 13. ENGINE SEALING

**Bell housing:** at least two of the bolts fastening the housing to the engine must be cross-drilled to provide sealing of the clutch/flywheel assembly; alternatively entrants may provide for sealing of the clutch and flywheel by cross-drilling at least two of the clutch cover retaining bolts.

## 14. MISCELLANEOUS

- 14.1** Engine components not covered by these Regulations must remain standard and unmodified. The requirement for the use of standard parts is deemed to mean the part, as defined by the part number, prescribed by the Ford Motor Co. spare parts listing for the appropriate engine. Unless otherwise specified herein, all parts shall be “standard” parts and further, unless specifically authorised they shall not be altered in any way; and they shall be assembled and fitted in the manner intended by the Ford Motor Co.
- 14.2** The use of titanium, high-strength composites and similar material is prohibited.
- 14.3** Each car may only be fitted with one data recording unit and unless otherwise specified one of each of the following sensors:  
**General sensors:** front wheel speed (x2); steering angle; G-force longitudinal; G-force lateral; G-force vertical; suspension position (x4); brake line pressure front; brake line pressure rear; battery voltage; oil temperature; cockpit temperature; beacon input: lambda; water pressure sensor.  
 Random data sampling may be undertaken by the Scrutineers or Technical Commissioner. Telemetry devices are prohibited.  
 The fitment of an electronic timing device as required by the circuit timing systems is permitted. Timing transmitters must be fitted, in accordance with the manufacturer’s instructions, with the leading edge at a position no less than 1.6m behind the point of the nose of the car, unless otherwise directed by meeting officials.
- 14.4** Communication systems (eg, radio, ~~mobile phone etc~~), designed to provide communication between the driver and pit during competition, are not permitted. **The communication system shall not be utilised for any other purpose.**
- 14.5** **Competition numbers and backgrounds:** All competitors in all national competition shall use competition numbers and backgrounds of common design and size.

The backgrounds shall be white, rectangular & defined by a 3mm black border. The background including border shall measure 190mm x 230mm. The numbers shall 165mm high, black, of the typestyle known as **ZURICH BOLD** (example shown here):

**1 2 3 4 5 6 7 8 9 0**

Each car must display its competition number in three locations: on the nose of the car, in a location visible to a person standing directly in front of the car at a distance of at least 10m; and one on each side of the car at a position between the rear of the driver and the leading edge of the rear wheel, at a minimum height of 300mm above the bottom of the car and above any sidepods.

#### 15. SPECIFIED COMPONENTS

All Specified components must remain as supplied unless these regulations state otherwise. **The following components are "Specified":**

Air filter	SN 2580
Air temperature sensor	Bosch – part no. 0280 130 039
Clutch plate	SC8460-FF-18
Clutch plate	SC8460-FF-20
Electronic control unit (ecu)	1002 FF
Exhaust collector	ENG0055-A
Exhaust flange	ENG0056-A
Flywheel	ENG0062-A ENG0062-CA
Fuel pressure sensor	MSE/100PSI
Fuel rail	FLS0137-A
Fuel supply block	FLS131-A
Ignition coil	4M5G-120 29-ZA
Ignition module	BIM 200
Inlet manifold plenum	ENG0071-A2
Inlet manifold runners	ENG0071-A1
Map sensor	MS-16 137 039
Oil pressure sensor	MSE/100PSI
Pcv cover plate	ENG0138-A
Scavenge pump	ZIP SE 10L
Sump	ZIP SE 1.6
Throttle body	ENG0063-A
Throttle position sensor	0 261 211 003
Water temperature sensor	Bosch – part no. 0280 130 026
Wheels	Performance Alloy Wheels:- part. no. 100FF or 095FF
Wiring loom	MSE F/FORD REV 1

#### 16. FOREWARNING OF POSSIBLE 2011 CHASSIS CHANGES

**The Ford Motor Company (UK), the RACMSA and the FIA have been working together toward a common set of safety regulations for tubular steel single seater chassis. This process has now been completed and some recommendations will be incorporated into the 2011 UK Formula Ford Regulations.**

Once details of the recommendations are available, consideration will be given to their introduction to Australian competition, as part of the ongoing process of aligning Australian regulations as closely as practicable to those in other countries.

All participants will be advised of the progress of these changes as soon as information is available.

## TABLE OF DIMENSIONS

## Appendix A

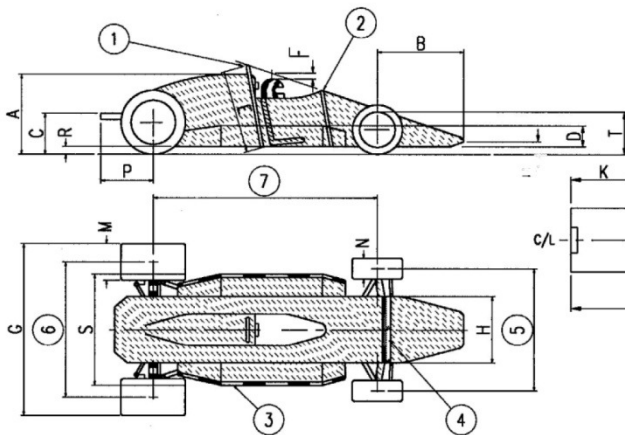

1. Safety roll over bar
2. Substantial support structure
3. Lateral protection structure
4. Substantial structure
5. Front track
6. Rear track
7. Wheelbase

### Notes

- Maximum height is measured with the driver aboard.
- Maximum height excludes safety roll-over bar on which there is no maximum height.

Single Seater dimensions – refer to drawing stated

All dimensions in mm unless specifically

(A) *	Maximum body height measured from ground	900
(B)	Maximum front overhang from front wheel axis	1000
(C)	Exhaust height measured from the ground	600 Max
(D)	Minimum height of Lateral Protection Structure	150
(E)	Minimum safety roll-over bar length in line with driver's spine	920
(F)	Minimum allowed helmet clearance	50
(G)	Maximum width	1850
(H)	Maximum body width behind front wheels	950
(J)	Minimum cockpit opening	450
(K)	Minimum cockpit parallel opening length	300
(L)	Minimum cockpit overall opening length	600
(M)	Maximum rear wheel width	7 inch
(N)	Maximum front wheel width	6 inch
(P)	Maximum exhaust length from rear wheel axis	600
(R)	Minimum ground clearance	40
(S)	Maximum width including lateral protection structure	1300
(T)	The maximum height of any part wider than 1100mm ahead of the front wheels is not to exceed the front rim height	
	Minimum wheelbase	2000
	Minimum track	1200
	Wheel diameters	13 inch

**(\* Except for within 450mm rearward of the front face of the roll bar and for a maximum of 150mm either side of the longitudinal roll bar centre line, where bodywork may be present but shall not be more than 25mm higher than the upper surface of the roll bar.)**

**END**